

Cautions and Warnings



DO NOT INSTALL ANY SIMPLEX® PRODUCT THAT APPEARS DAMAGED. Upon unpacking your Simplex product, inspect the contents of the carton for shipping damage. If damage is apparent, immediately file a claim with the carrier and notify an authorized Simplex Product Supplier.



ELECTRICAL HAZARD - Disconnect electrical field power when making any internal adjustments or repairs. All repairs should be performed by a representative or authorized agent of your local Simplex product supplier.



STATIC HAZARD - Static electricity can damage components. Handle as follows:

- Ground yourself before opening or installing components.
- Prior to installation, keep components wrapped in anti-static material at all times.

FCC RULES AND REGULATIONS – PART 15 — This equipment has been tested and found to comply with the limits for a Class A digital device, pursuant to Part 15 of the FCC Rules. These limits are designed to provide reasonable protection against harmful interference when the equipment is operated in a commercial environment. This equipment generates, uses, and can radiate radio frequency energy and, if not installed and used in accordance with the instruction manual, may cause harmful interference to radio communications. Operation of this equipment in a residential area is likely to cause harmful interference in which case the user will be required to correct the interference at his own expense.

Introduction

The TrueAlert family of notification appliances provides addressable control and supervision of individual appliances and circuit wiring. Appliances are operated over a single two-wire notification appliance circuit (TrueAlert Channel) that allows T-tapping (Class B only). The TrueAlert Isolator + Module provides a means of containing the effects of a short circuit on the TrueAlert Channel to a single segment of wire, as well as an aid in locating stray connections to earth ground. The TrueAlert Channel can be broken into segments called Virtual NACs (VNACs) in both Class B and Class A circuit topologies using the TrueAlert Isolator + module to abut segments. TrueAlert Isolator + Modules operate contact switches through commands received over the 2-wire TrueAlert circuit from the 4009 TrueAlert Addressable Controller and TrueAlert Power Supply (TPS). TrueAlert Isolator + modules automatically isolate the short to a single segment of wire, but require a command from the host panel to restore the connection. Manual control of opening and closing the contacts is also available through the TrueAlert Power Supply.

The range of possible temperatures under which the TrueAlert Isolator + can function is between 0° C (32° F) and 49° C (120° F).

The TrueAlert Isolator + operates normally under non-condensing humidity conditions up to 93% with relative humidity at 38° C (100° F).

The TrueAlert Isolator + Module has a LED that the TrueAlert Addressable Controller can command to Flash ON, OFF, or blink when polled. See Figure 1, TrueAlert Isolator + Module.

Note: The TrueAlert Isolator + Module is a faster version of the original TrueAlert Isolator. It is a 100% backwards compatible replacement for the original version. You will not necessarily gain the enhanced speed benefit of the short isolation unless all your isolators are the new “+” type on the same TrueAlert Channel. The “+” version can be identified by looking at the silkscreen on the PCA for “TrueAlert Isolator +” located near the terminal block.

Installation instructions, *Continued*

In this Publication This publication discusses the following topics:

Topic	See Page
TrueAlert Isolator + Wiring	2
TrueAlert Isolator + Class B Wiring	3
TrueAlert Isolator + Class A Wiring	4
Mounting the TrueAlert Isolator + Module	5
Setting the TrueAlert Isolator + Module Address	6

TrueAlert Isolator + Wiring

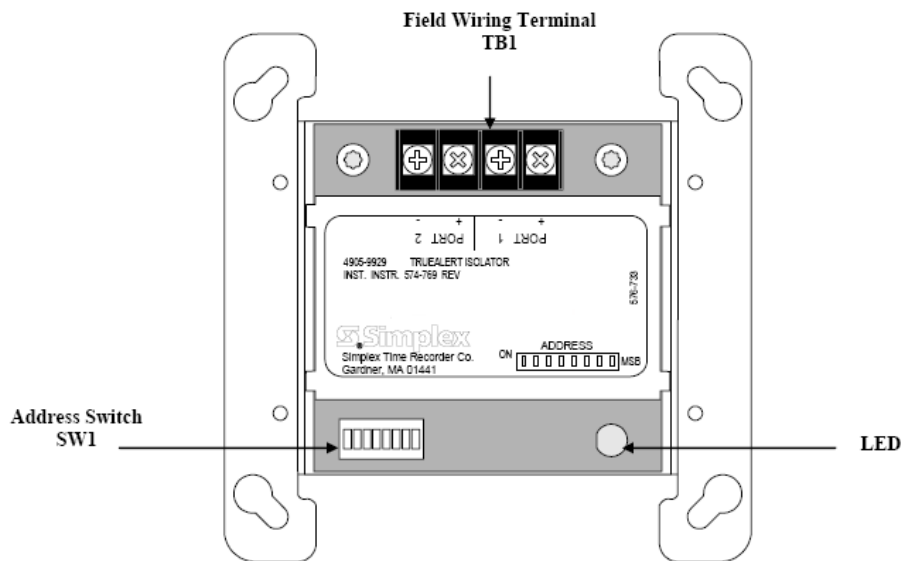

Figure 1. TrueAlert Isolator + Module

Warning: Make sure that all power is disconnected before starting the installation.

Caution: Connect Wiring to terminals as shown. Do not loop wires under terminals. Break wire runs to provide supervision of connections. Do not bring conduit through the rear of the electrical box. Strip lead insulation to 3/8" maximum.

1. At the electrical box, connect the contractor wire to the PORT 1/PORT 2 (+ and -) terminal of the TrueAlert Isolator + Module. See figure 2 and 3, TrueAlert Isolator + Class B and A Wiring.
2. Ensure that correct polarity is maintained across the ports.
3. Ensure that the CKT +'s or -'s are not crossed between ports.
4. Do not loop wires under the terminals.

Installation instructions, *Continued*

TrueAlert Isolator + Class B Wiring

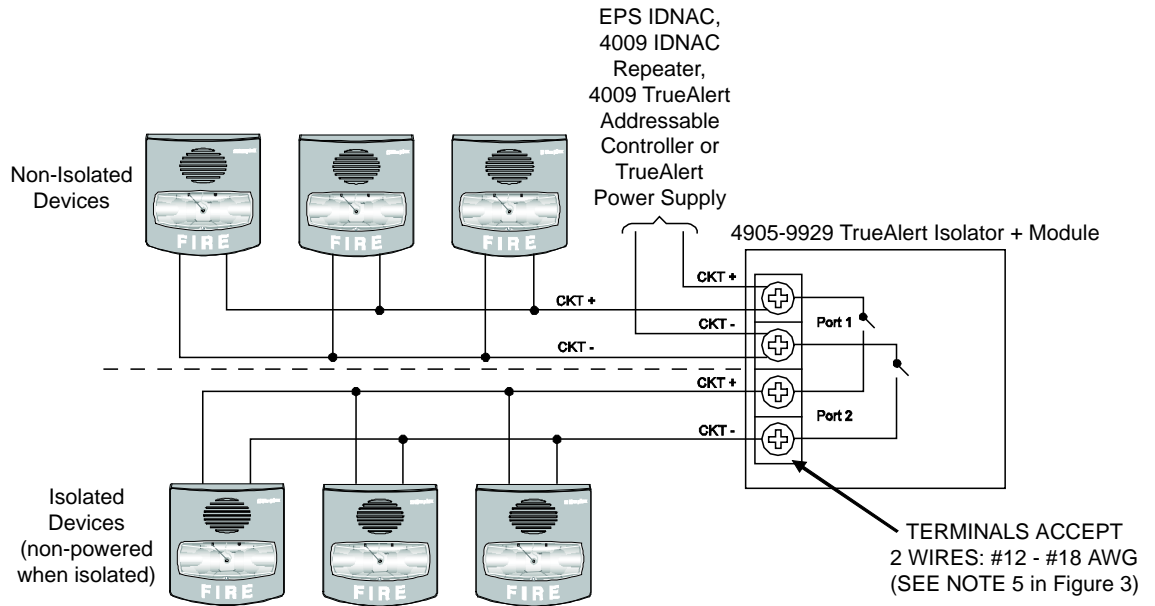

Note:

On any segment of wire protected by one or more Isolator+ modules, limit the wire resistance to a maximum value of 1.5 ohms for a given line path. The wire resistance is measured from the Controller's port to the furthest appliance in the protected segment. Deviation from this limitation does not guarantee isolation for short-circuits that are located greater than 1.5 ohms.

Figure 2. TrueAlert Isolator + Class B Wiring

Installation instructions, *Continued*

TrueAlert Isolator + Class A Wiring

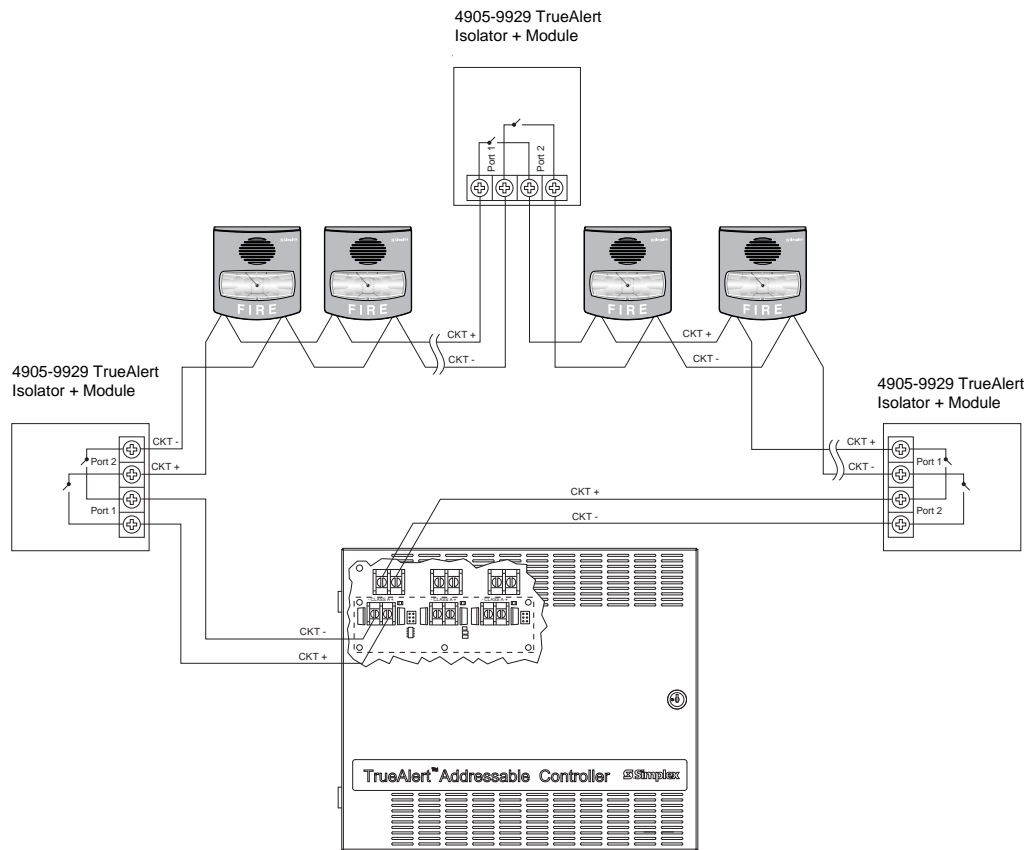

Notes:

1. Refer to the field wiring diagrams or the installation manual supplied with the applicable system for detailed circuit wiring information. No more than 6 Isolator + Modules can be connected at any port.
2. Limit the wire resistance to a maximum value of 1.5 ohms for a closed line path in the SLC wiring. Deviation from this limitation does not guarantee isolation for short-circuits that are located greater than 1.5 ohms.
3. Notification Appliances are rated per individual nameplate label.
4. Maintain correct polarity on terminal connections. Do not loop wires under terminals.
5. All circuit wiring connections are supervised and power-limited.
6. Powering the Isolator + Module from an appliance power source less than 17.6 VDC or greater than 32 VDC may cause permanent damage to the module.
7. The TrueAlert Isolator + Module can be operated through the TrueAlert Addressable Controller, the TrueAlert-compatible FACP, the 4009 IDNAC Repeater or the EPS IDNAC.
8. The Isolator + Module counts for 4 unit loads on the TrueAlert Channel. De-rate alarm load line voltage drop allowance by 0.06 V/amp of alarm current per Isolator + Module.
9. T-tapping is not allowed for Class A wiring. For Class B wiring, T-tapping is allowed. Refer to the field wiring diagram for maximum T-tapping length.
10. The TrueAlert Isolator + current draw is 10 mA maximum over its operating range.

Figure 3. Typical TrueAlert Isolator + Class A Wiring

Installation instructions, *Continued*

Mounting the TrueAlert Isolator + Module

The TrueAlert Isolator + module mounts to the 4-inch square grounded metal electrical box via 2 screws. Box depth is dependent on the number and size of conductors used in a particular application. The range extends from a minimum 2 1/8" deep box to a 1 1/2" deep box with a minimum 1 1/2" extension ring.

Caution: Do not bring conduit through the rear of the electrical box.

1. Tighten mounting screws snugly (do not over-tighten).
2. For semi-flush mounting, install the box either flush with the wall or with a maximum 1/4-inch recess.

The TrueAlert Isolator + Module uses terminals to connect to each wire point. Each accepts 2 wires of gauges #12 through #18 AWG. The terminal screws at TB1 accommodate both slotted and Philips drive.

Refer to the Field Wiring Diagrams, or applicable installation manuals, for detailed information on maximum wire run distance.

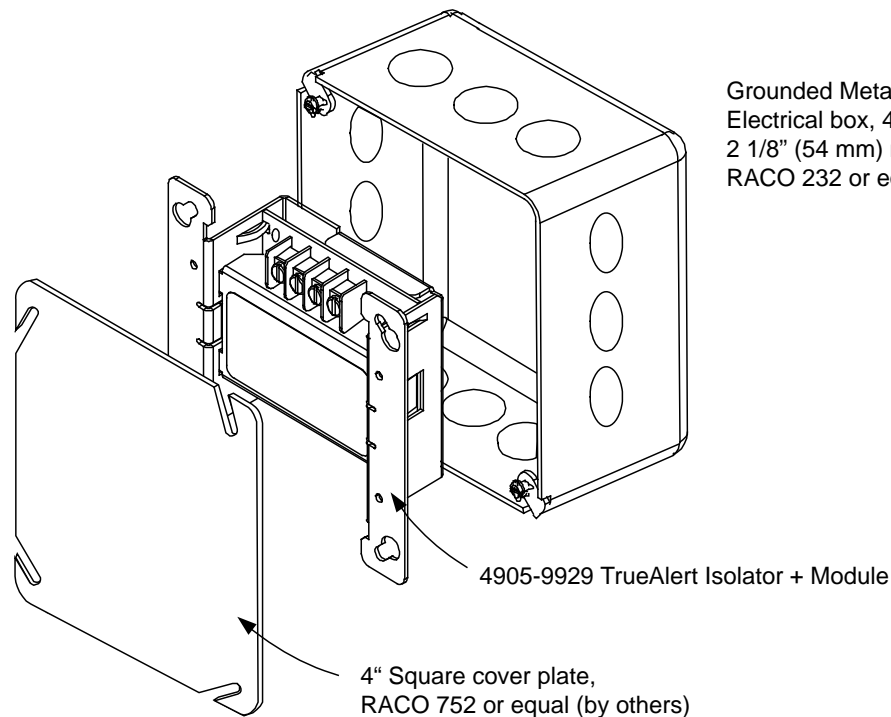

Note: A cover plate (not supplied) is required to complete installation

Figure 4. TrueAlert Isolator + Mounting

Installation instructions, *Continued*

Setting the TrueAlert Isolator + Module Address

The True Alert Isolator + has a unique address. Each device's address is set via an eight-position DIP switch, as shown in Table 1. See Figure 1 for the general DIP switch location. DIP switch position 1 is the least significant bit (LSB) and position 8 is the most significant bit (MSB).

Note: DIP Switches 1 through 6 are used to set the possible 63 address codes, DIP Switches 7 and 8 are not used and are set to "OFF".

Use a small screwdriver or pen to set the switches, and then write the address on the resealable label. This information provides an aid in troubleshooting the system.

Notes:

1. The TrueAlert Channel (4009 TrueAlert Addressable NAC Controller or TrueAlert compatible FACP only) supports address codes 1 through 63.
2. DIP switch in "1" position is "ON" while DIP switch in "0" position is "OFF".

Table 1. TrueAlert Isolator + Module – DIP Switch Address Chart

